

FOCUS



ON

FAITH

Volume 47, Number 1
2018



Sunday School—9:00 am
Worship—10:15 am

PASTOR: Rev. Dr. Bruce C. Stevenson
DIRECTOR OF MUSIC/ORGANIST: Dennis J. Duda

Faith United Church of Christ

5992 Route 378
Center Valley, PA 18034
610-282-3939
Office@faithchurchucc.org
www.faithchurchucc.org



Thank you to the newsletter crew for their help in mailing the newsletters each month -

Arlene Beck, Ruth Cressman, LaVerna Diehl, Joan Hassler, Evelyn Hovis, and Sue Walter

2017-18 Consistory

President: Wes Koser
Vice President: Deb Orach
Secretary: Michele Keeler

Elders:

Mim Allison
Deb Orach
Wes Koser
Jane Van Horn

Deacons:

Michele Keeler
Qiyi Zhu Stoffey
John Barone
Kevin Long

Colleen Kandt
Barb Scattergood
Tom Berghold
Mary Ellen Long

Church Treasurer: Joe Orach

Liaisons:

Christian Ed— John Barone
Fellowship/Outreach—John Barone
Property—Wes Koser
Worship—Mim Allison
Mission—Barb Scattergood
Day Care—Colleen Kandt

Kitchen Krew—Jane Van Horn
Enduring/Memorial—Mary Ellen Long
Staff Relations—Qiyi Zhu Stoffey
Budget & Finance—Deb Orach
Youth Group—Kevin Long
Fundraising—Michele Keeler

*We are a people
who have come together
through a common faith,
a common love,
and a common covenant
with the triune God;
Father, Son, and Holy Spirit,
and together we endeavor
to be a community of
worship,
education,
mission,
fellowship,
and stewardship.*



A NOTE FROM THE PASTOR

Dear Friends,

Another new year is about to begin and like many people I am reflecting on the year behind me and considering things that I could do to make my life better in the year ahead. You know what I'm talking about ... New Year's Resolutions! I've made them before: lose weight, exercise more, save a little more money for a "rainy day," build a pergola (☺), etc., and to a certain extent I have succeeded at all of them.

This year I am going to take a different approach. This year I am not going to place losing weight, exercising, or saving money, etc. at the top of my list. This year I'm going to make it simple. I'm going to make myself happier. I know that sounds a little selfish but I think that if we make ourselves happier in general the greater challenges we have in life will become much easier to take on and conquer. Evidently being happier needn't be so difficult. Recently I read an article in the New York Times entitled *4 Easy(ish) Steps Towards Happiness You Can Take Today*. Let's take a quick look at these steps.

1. Conquer Your Negative Thinking

As human beings we have evolved to focus on the negative. If we over learn a bad situation, we're more inclined to avoid those situations in the future or react more quickly, writes Tara Parker-Pope in our happiness guide. But, as we all know, that isn't always helpful in a modern world. When something bad happens, we tend to overanalyze and have trouble getting our mind off it.

The trick to avoiding those spirals and rabbit holes of misery is

to acknowledge and challenge our negative thoughts. Rather than try to bury them, we should own those thoughts and ask ourselves a few questions, like, “What is the evidence for this thought?” or “Am I basing this on facts or on feelings?” A little self-investigation can help us get over the thoughts that just won’t leave our heads otherwise.

2. Forgive Yourself

This one is really simple: Go easy on yourself. If you’re compassionate and supportive of other people, why shouldn’t you give yourself the same luxury?

This can be a difficult concept for those of us who tend to beat ourselves up over perceived failures, so our guide has an exercise you can use to practice. Write yourself a letter of compassion just as you would to a neighbor or friend who had experienced a hardship. The concept is the same, only the recipient is you.

3. Money Helps, But Only to a Point

An often-cited study from a few years ago boldly named the amount of money at which happiness peaks: \$75,000 per year. Another recent (but less rigorous) examination put that number at \$100 million. Still another study said lottery winners are no happier than the rest of us.

Interesting!

The truth is, we’re plagued by the constant craving for the next thing. Tara calls this the “hedonic treadmill” in the happiness guide and, essentially, we’re stuck on it. A more helpful way to look at this idea is to find purpose and meaning at work. Rather than focusing on work as a means to earn money, try to find

genuine satisfaction and purpose in the work you do. Studies have shown this is possible in every type of job.

4. Buy More Time

If given the choice between buying material things and buying services that save you time, you might want to think about the timesavers.

In two surveys cited in our guide to happiness, researchers found that people who spent money on conveniences like ordering take-out for dinner or getting a cab were happier than those who didn't.

So what does that mean for you? If you can afford it, buy yourself some extra time. (Yes, this is permission to order a pizza for dinner tonight.)

So, these are four steps towards happiness that I am going to take during 2018. Thank you Tim Herrera of the New York Times! If you have anymore that you'd like to share I'd love to hear them! Have a HAPPY New Year!

Peace,



To see the *happiness guide* mentioned, go to:
www.nytimes.com/guides/well/how-to-be-happy



Answer: Therefore, if anyone is in Christ, the new creation has come:
The old has gone, the new is here! 2 Corinthians 5:17, NIV

Exciting News!

It has been a long time since Linda Lenhart, Director of Youth Discipleship, ended her ministry with us to move on to new challenges in her life. Now that our mortgage is paid off we are confident that we can support a position on our staff that focuses on the faith formation of our youth and family ministries. After interviews and several in depth meetings we are happy to report that the Rev. Joshua Knappenberger will be joining our staff as our Pastor of Discipleship for 15 hours a week starting January 14, 2018. We look forward to receiving Josh's ministry in the areas of Christian Education, Youth, and Family Ministries. We will have a coffee hour in Fellowship Hall immediately following worship that morning for you to meet Josh and his family. Please be sure to stop in and say "Welcome!"



The Church Office
will be closed
December 25—January 1, 2018
and
January 15
in observance of
Martin Luther King, Jr. Day

Greetings to you, people of Faith UCC,

I am Reverend Josh Knappenberger, and I love stories. I believe the ability to tell stories is one of the great gifts God has given us. Storytelling is an ability each of us possesses, and without it, our relationships with each other and the rest of our human brothers and sisters would die before they had the chance to live.

January 14th, 2018 will mark the beginning of my relationship with you, the people of Faith UCC, and so I will tell you my tale. On the surface, it is a simple one but, as with your own stories, just beneath that facade lies a beautiful complexity that has been interwoven by God.



In late August 1982, I was born in an Allentown hospital. My mom gave birth to me, my dad caught me on the way out, and my only sister, older than me by five years, was the first person to hold me in her arms. They say all babies are cute but I've seen pictures of me and, trust me, with my scrunched face, furrowed brow, and black hair, I was an ugly baby. Nevertheless, my parents took me home.

I think my ugliness subsided as I grew.

Through my formative years, I was brought up in the church and experienced much of what is meant by the costs and joys of discipleship. After graduating high school, I felt God pulling me

into the service of our nation. I joined the Army and served in the Army's ceremonial unit in Washington DC. Over the course of three and a half years, I performed funerals in Arlington National Cemetery and spent a year on special assignment as a Pentagon tour guide.

I left active duty in 2005 but continued service in the reserves for the following seven and half years while pursuing higher education. Through much prayer in my first semester of college, I accepted God's call to the ministry and to serve Christ's Gospel of love in the world.

As my college days came to a close, I met and fell in love with my wife, Angela. We married two and half years later in December 2010.

My seminary studies were vast, and they took me abroad. I spent four weeks of one of my summers digging in the sands of Israel with an archaeological expedition at Tel Rehov. In my site-seeing in the Holy Land, I stood at the Mount of Olives with olive trees that, at roughly three thousand years old, observed our Lord and Savior as his sweat became droplets of blood through his prayers of anguish at his impending death.

I was ordained in November 2013 and accepted my first full-time call to a Berks County church in the spring of 2014. And in the midst of my work at that church, My wife and I were blessed to bring to this another great story of God's as our daughter Cora was born. In our short time in Berks County with a child, we began to feel the distance between us and our families' in the Lehigh Valley. That distance combined with differences in the church

between my leadership and the congregation led us to follow God’s call back to the Lehigh Valley where we currently live in the West end of Bethlehem.

Since resigning my full-time position in the church, I have primarily become a stay-at-home dad. Staying at home with my daughter has been a wonderfully blessed time of my life.

As I wrote above, I love stories. The only thing I enjoy more than hearing or reading stories is writing them. I have used my recent “in between” time to become a published author. My book is called “The Lion and The Savior: A Spirit Guide’s Journey.” It is only available on Kindle at the moment, but I plan to have it ready for hard copy release in 2018.

Thank you for taking the time to read my story. What I have told you is merely the tree of the story, and just beneath the surface is a complex and beautiful root system of stories that bring more life to the tale you have just read. I look forward to sharing that complexity with you in the days ahead.

And so, I have told you my tale—what is your story? I can’t wait to hear it.

Blessings,

Pastor Josh

Within Our Church Family

New
Address!



Mim & Joe Allison
6385 Vera Cruz Rd
Center Valley, PA 18034
Phone: 610-533-1310

(Updated Directories are available in the Narthex. A link to the directory is also included on the weekly emails sent out.)

Pastor Bruce & Faith Friends,

Thank you very much for your enjoyable visit and for the Christmas Bag full of gifts.

The Lap Blankets are so nice.

The Christmas picture of the church is beautiful! Happy New Year!



*Thank You,
LaMar & Arlene Beck*

~~oops!~~

From a worship PowerPoint:

Son of God, love is pure light

Radiant beams from thy holy face

With the dawn of redeeming grace

This likely caused *beams* of laughter during the candlelight service!

THOSE WHO WILL SERVE IN JANUARY

Head Usher: Colleen Kandt
Nursery: Catherine Stevenson

	January 7	January 14	January 21	January 28
Greeter	Cathy Wimmer	Diane Neidermeyer	Sue Walter	Dennis & Caroline Frantz
Ushers	Bob & Patti Shelly Donna Schoenberger	Tom & Brenda Hovis Chuck & Karen Talboo	tbd	tbd
Lay Reader	Chuck Talboo	Brenda Hovis	tbd	tbd
Acolytes	Damyn Allison Weiland Hite	Avery Koser Noah Ritter	Noah Jellison Morgan Webb	Connor Licairac Avery Koser
Nursery Helper	Tbd	Tbd	Tbd	tbd
Flowers	Hassler	Available	Available	Available
Financial Secretary	Doug Hutchinson	Doug Hutchinson	Doug Hutchinson	Doug Hutchinson



FROM THE TREASURER— NOVEMBER FINANCIALS

NOVEMBER	INCOME	EXPENSE	Last Year	
Receipts	\$20,739	\$238,139	\$20,235	\$207,634
Disbursements	\$19,067	\$243,560	\$19,702	\$209,527
	\$1,672	(\$5,421)	\$533	(\$1,893)

	Weekly Attend.	Weekly Offering	over/under \$3500 goal
11/5	68	\$ 2,637	(\$863)
11/12	91	\$ 3,193	(\$308)
11/19	93	\$ 2,939	(\$561)
11/26	128	\$ 2,257	(\$1,243)
Total	380	\$ 11,026	\$ (2,974)

Special Offerings:

Betty Lou's Pantry—\$95

Samaritan Fund—\$50

Basket Bingo Income: \$3,600

2017 Offering must be received in the Church Office by Monday, January 8, 2018. Offering received after the 8th will be credited to 2018.

Your **2018 Offering Envelopes** are in the Narthex. If you don't have envelopes but would like some, or have them but don't use them, please call Sandy at 610.282.3939.



From the Secretary:

The **deadline** for **February Newsletter** articles and information is **January 10th**. Please email to faithchurchcv@gmail.com or place them in the Secretary's mailbox in the conference room.

2018 ALTAR FLOWER SCHEDULE is hanging in the Narthex. Place your name and bulletin listing next to the date you want to reserve. Please hold your payments until January 2018. The cost will remain \$34 for the new year.



Many thanks for your support of Betty Lou's Pantry! For the last three Sundays of October and the first two Sundays of November, our regular donations included 222 items and \$261. Currently, over 100 families are being assisted. All of the recipients are very grateful for your generosity.

MOST NEEDED ITEMS:

**LIQUID LAUNDREY DETERGENT • CANNED PASTA • BAKED BEANS
CANNED TUNA • BOXED POTATOES • CHUNKY/HEARTY SOUPS
BOXED PASTA (NO SPAGHETTI) •**

Items stocked at the Pantry include:

- | | |
|-----------------------------|--------------------------------|
| Pork & Beans | Chili |
| Canned Fish (salmon) & Meat | Canned Pasta |
| Peanut Butter | Canned Tomatoes & Canned Sauce |
| Kidney & Black Beans | Chunky Soups |
| Canned fruit | Macaroni & Cheese |
| Canned Tuna | Canned Vegetables |
| Beef Stew | Dry Pasta & Spaghetti |
| Spaghetti Sauce | Canned Tuna |

Monetary Donations are a particularly effective way to help the Pantry. A donation of \$10 will buy over 60 lbs of food through Second Harvest. If you are in need or know of someone in the area who is, please call **610-282-2838** and leave a message, or email bettylouspantry18036@gmail.com

—Mike Ford

Mission News



In 1990 the Souper Bowl of Caring began with a simple prayer from a youth group in South Carolina. The prayer was simply this: “Lord, even as we enjoy the Super Bowl football game, help us be mindful of those who are without a bowl of soup to eat”.

Since then, more than \$110 million has been raised and donated to organizations that provide shelter to the homeless and food for the hungry. Right here in the Southern Lehigh area, Betty Lou’s Pantry provides food for over 100 families and 300 individuals, many of whom are children.

The Mission Team would like to challenge all of you to support the **Souper Bowl of Caring** by bringing several of these food items ***EVERY Sunday starting January 14 through February 25:***

BEEF STEW

HEARTY SOUP

CHILI

We challenge the congregation to donate at least **125** cans of soup. Donations can be left in the Narthex in the bin marked for **Souper Bowl of Caring**. **THEN...In February**, we will be holding a “**Soup Cook-Off**” after worship. Start planning now to bring your favorite soup to share and maybe your recipe will be Faith Church’s Best Winner! More details will be available in the February Newsletter.

I am sure that many of you will be gathering with friends and family to watch the Super Bowl. There will more than likely be an abundance of snacks and beverages. As we gather for this event let us not forget our neighbors in need and help to provide a family with a hot bowl of soup on a cold winter’s night.

Congratulations to Kraig Koehnlein!



Kraig received his Eagle Scout award at a ceremony here at Faith UCC on Sunday, November 26, 2017. Kraig's Eagle Scout project was refurbishing the bench and surrounding area outside the church sanctuary. Kraig has participated in Cub Scouts and Boy Scouts since 2006. In addition to his Eagle Scout award, Kraig was also awarded his silver palm for earning 15 additional merit badges beyond the 21 required for Eagle. Outside of Scouting, Kraig is a senior at Southern Lehigh High School where he is a varsity member of the track and field team throwing the javelin, discus, and shot-put. In addition, Kraig is also a member of the High School Key Club. Next fall Kraig plans on attending Bloomsburg University.



SOUTHERN LEHIGH MEISTERSINGERS





JANUARY BIBLE READINGS

January 1

Isa. 62:6–7, 10–12
Heb. 2:10–18
Matt. 1:18–25

January 2

Gen. 12:1–7
Heb. 11:1–12
John 6:35–42, 48–51

January 3

Gen. 28:10–22
Heb. 11:13–22
John 10:7–17

January 4

Exod. 3:1–5
Heb. 11:23–31
John 14:6–14

January 5

Josh. 1:1–9
Heb. 11:32–12:2
John 15:1–16

January 6

Isa. 52:7–10
Rev. 21:22–27
Matt. 12:14–21

January 7

Isa. 52:3–6
Rev. 2:1–7
John 2:1–11

January 8

Isa. 40:1–11
Heb. 1:1–12
John 1:1–7, 19–20,
29–34

January 9

Isa. 40:12–24
Eph. 1:1–14
Mark 1:1–13

January 10

Isa. 40:25–31
Eph. 1:15–23
Mark 1:14–28

January 11

Isa. 41:1–16
Eph. 2:1–10
Mark 1:29–45

January 12

Isa. 41:17–29
Eph. 2:11–22
Mark 2:1–12

January 13

Isa. 42:(1–9) 10–17
Eph. 3:1–13
Mark 2:13–22

January 14

Isa. (42:18–25) 43:1–
13
Eph. 3:14–21
Mark 2:23–3:6

January 15

Isa. 43:14–44:5
Heb. 6:17–7:10
John 4:27–42

January 16

Isa. 44:6–8, 21–23
Eph. 4:1–16
Mark 3:7–19a

January 17

Isa. 44:9–20
Eph. 4:17–32
Mark 3:19b–35

January 18

Isa. 44:24–45:7
Eph. 5:1–14
Mark 4:1–20

January 19

Isa. 45:5–17
Eph. 5:15–33
Mark 4:21–34

January 20

Isa. 45:18–25
Eph. 6:1–9
Mark 4:35–41

January 21

Isa. 46:1–13
Eph. 6:10–24
Mark 5:1–20

January 22

Isa. 47:1–15
Heb. 10:19–31
John 5:2–18

January 23

Isa. 48:1–11
Gal. 1:1–17
Mark 5:21–43

January 24

Isa. 48:12–21 (22)
Gal. 1:18–2:10
Mark 6:1–13

January 25

Isa. 49:1–12
Gal. 2:11–21
Mark 6:13–29

January 26

Isa. 49:13–26
Gal. 3:1–14
Mark 6:30–46

January 27

Isa. 50:1–11
Gal. 3:15–22
Mark 6:47–56

January 28

Isa. 51:1–8
Gal. 3:23–29
Mark 7:1–23

January 29

Isa. 51:9–16
Heb. 11:8–16
John 7:14–31

January 30

Isa. 51:17–23
Gal. 4:1–11
Mark 7:24–37

January 31

Isa. 52:1–12
Gal. 4:12–20
Mark 8:1–10



NEW YEAR'S NOISE-MAKERS

Ring in the New Year with these fun noisemakers!



What you need:

- Wooden craft sticks
- Metallic paint (gold and silver)
- Paint brushes
- Jingle bells (gold and silver)
- Hot glue gun
- Metallic ribbon
- Scissors
- Adult help

What you do:

1. Paint half the sticks gold and half silver. Let dry.
2. Glue three bells to each stick.
3. Cut a six-inch piece of ribbon for each stick. Tie a bow and glue it to the noisemaker. Celebrate!

January Birthdays

01 Daniel George	22 Koltin Leh
01 Eric Schoenberger	25 Matthew Talboo
01 Justin Koser	27 Luke Schafer
02 Sandra Biery	27 Riley Snyder
04 Jameson Hughes	28 Ronald Stoffey
04 Liam Shelly	30 Leah Connors
05 John Marple	31 Gail Clark
09 Dennis Eisenhart	31 Matthew Allison
10 Jared Gunther	
10 Preston Amato	
13 Joan Hassler	
13 Thomas Heineman	
15 Stanley Turel	
15 Andrew Sosnowsky	
16 Robin Davis	
19 Dwayne Schantz	
21 Richard J Featherman	
21 Christian Heaps	
22 Christian Miller	
22 Chris Thompson	



Please call the church office with any omissions or corrections.

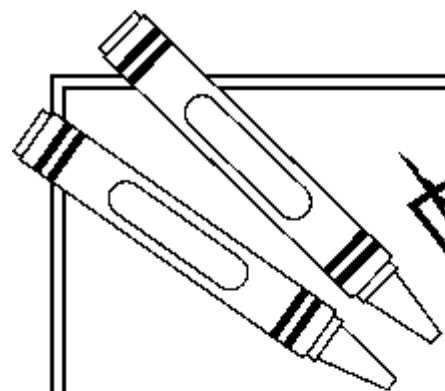

PUZZLE

A NEW CREATION



The apostle Paul says everyone who believes
in Jesus becomes brand new.



*Directions: Cross out every third letter. Then write the remaining letters in the
blanks to complete 2 Corinthians 5:17, NIV.*

T	H	I	E	R	O	E	F	Q	O	R	X	E	I	D	F	A	M	N	Y	A	O	N	
S	E	I	L	S	I	T	N	C	V	H	R	K	I	S	D	T	T	B	H	E	W	N	E
Q	W	C	D	R	E	Y	A	T	M	I	O	C	N	H	F	A	S	W	C	O	R		
M	E	G	T	H	W	E	O	F	L	D	X	H	A	S	S	G	Z	O	N	L			
E	T	J	H	E	W	N	E	Q	W	I	D	S	H	R	E	R	O	E					

_____ ! 2 CORINTHIANS 5:17, NIV